



Telephone Bell (for outdoor use) TAW

**Polarised AC bell for use as
second telephone bell
in private branch exchanges**

- ▶ Housing of plastic, glass-fibre reinforced
- ▶ Surface mounting
- ▶ Polarity reversal protection
- ▶ Separate terminal enclosure

Application

The TAW telephone bell is intended for use as additional acoustic signalling device to announce incoming telephone calls in noisy surroundings and/or outside.

Design

The TAW telephone bell consists of a glass-fibre reinforced plastic housing of protection degree IP 43 containing an electromechanical bell system and two steel domes. It can be connected directly to a private branch exchange. The separate terminal enclosure guarantees easy installation.

Secondary telephone bell for outdoor use

The TAW telephone bell is intended for use as additional acoustic signalling device to announce incoming telephone calls in noisy surroundings and/or outside.



Technical specifications

Housing	Plastic, glass-fibre reinforced
Colour	Grey
Protection degree	IP 43
Cable gland	On top or the side
Volume	Approx. 85 dB(A) (Regarding volume specifications, please see the chapter "Technical Informations".)
Impedance	8 k Ω
Temperature range	-20° C to +60° C
Weight	1.0 kg

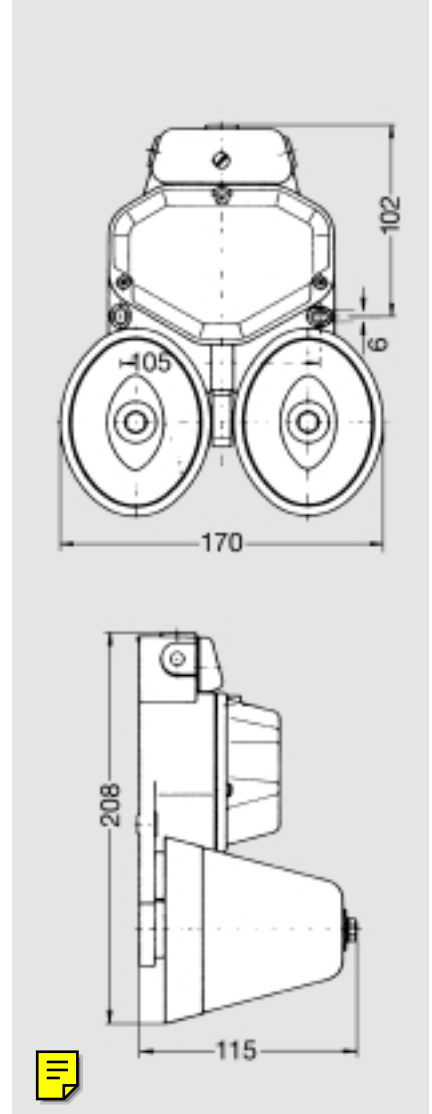

Order information

Type	Name	Version	Rated voltage V	Rated current A	Article no.
TAW	Telephone Bell	Surface mounting	45–50 V/23–54 Hz	12 mA at 50 VAC	211 101 01

